



Smith & Loveless Inc.  
Above All Others.

# OBEX™ Spiral Fine Screen



Waste from residents of a condominium complex in North Carolina is separated by the **OBEX™** Spiral Fine Screen (at left of photo), then sent on to the **TITAN MBR™** for treatment (in the background) .

## Trash and Debris Removal for Treatment Systems

Smith & Loveless takes its prominence in water and wastewater products even further with the **OBEX™** Spiral Fine Screen system, complete with PLC controls and a color HMI screen. The **OBEX™** Spiral Fine Screen system is a high-performance system which protects equipment and enhances plant operations by removing trash items and debris from treatment processes.

Small solids are captured by the front of the screen. Brushes then clean the front of the screen and allow the solids to be carried up the trough to discharge out the top for final disposal.

Because screen opening requirements vary greatly depending upon the application, Smith & Loveless offers a wide size range of screen opening diameters from .0098" (.25 mm) to .394" (10 mm). Smith & Loveless uses wedge wire material for openings sized .0098" (.25 mm) to .118" (3 mm) and perforated plate for openings sized .118" (3 mm) to .394" (10 mm).

The **OBEX™** Spiral Fine Screen can be mounted in an inlet channel or comes equipped with a self-contained tank mounting to a solid surface.

## OBEX™ Features

- Robust Stainless Steel (304 or 316) Construction
- Low rotational speed
- Easy maintenance
- Self-cleaning
- High capture rate
- Up to 7 MGD (1105 m<sup>3</sup>/d) Capacity (with 1/4" or 6 mm screen openings)



The **OBEX™** Spiral Fine Screen can be mounted on any flat surface, including the side of this **TITAN MBR™** treatment system.

**Flow Rate for the OBEX™ Spiral Fine Screen**

MODEL	1.0/1.0C/ 1.0F/1.0CF		1.5/1.5C/ 1.5F/1.5CF		2.0/2.0C/ 2.0F/2.0CF		3.0/3.0C/ 3.0F/3.0CF		4.0/4.0C/ 4.0F/4.0CF		6.0/6.0C/ 6.0F/6.0CF		7.0/7.0C/ 7.0F/7.0CF	
SCREEN SIZE (MM)	MGD	M³/Hr	MGD	M³/Hr	MGD	M³/Hr	MGD	M³/Hr	MGD	M³/Hr	MGD	M³/Hr	MGD	M³/Hr
WW 2.0	0.57	90.0	0.70	110.0	0.92	145.0	2.06	325.0	2.79	440.0	4.22	665.0	5.08	802.0
PS 3.0	0.63	100.0	0.82	130.0	1.17	185.0	2.08	328.0	2.91	459.0	4.78	754.0	5.64	890.0
PS 6.0	1.00	158.0	1.26	198.0	1.93	305.0	2.79	440.0	3.82	602.0	6.28	991.0	7.04	1,110.0

Note: C=Compactor; F=Flanged Box, CF= Compactor Flanged Box

**OBEX™ Spiral Fine Screen Options**

**Compactor**

The compactor, located at the discharge end of the auger, provides for up to a 40% reduction in screenings volume. A drainage tube is connected from the compaction area and discharges back into the trough or tank.

**Discharge Chute**

The discharge chute mounts to the discharge section of the screen. Material choices include a stainless steel tube, PVC or vinyl hose. The length of the chute can be made to match the specific installation.

**Bagger System**

A bagger system at the discharge end of the chute collects screenings and bags them for disposal. The continuous polybag is mounted in a frame and is water-proof to prevent additional drainage of the screenings.

**Spray Wash System**

A spray wash system can be provided for the screen, transport tube and/or compaction areas. The system consists of a solenoid valve and spray header mounted to a screen. Wash water requirements are a minimum of 15 GPM at 35 psi (1 L/sec at 2.5 Bar).

**Bypass**

A screen bypass is available on the OBEX™ Spiral Fine Screen with Tank. The bypass consists of a box mounted on the side of the tank to allow unscreened water to flow around the screen basket and into the downstream treatment process, or with a bypass pipe, to an alternate location. The bypass option is not recommended for MBR applications because bypassing the OBEX™ Spiral Fine Screen can damage the membranes.

**Numerous Applications for the OBEX™ Spiral Fine Screen Systems**

S&L's Inlet OBEX™ Spiral Fine Screen systems can benefit customers in a wide range of applications:

- Wastewater treatment systems, including MBR systems
- Grit removal
- Pump Stations
- Storm water treatment
- Food processing; a wide range of applications including:
  - \* Fish processing, Meat processing, Rendering plants, Food waste disposal, Beverage processing, Nut processing, and Wineries
- Correctional institutions
- Military facilities
- Governmental
- Residential developments
- Resorts & Casinos
- Condominium Complexes
- Hotels
- Nursing & Medical Facilities
- Boat harbors

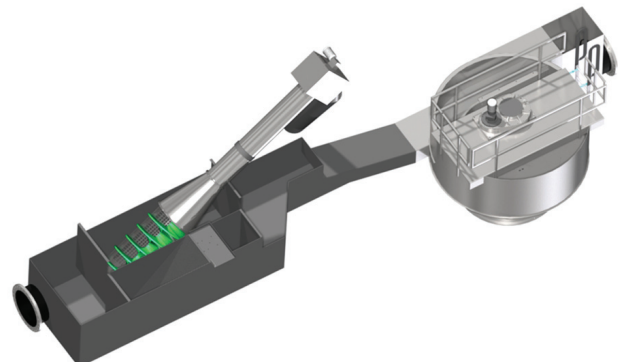

3D model of the inlet channel mounted OBEX™ Spiral Fine Screen assembly used with PISTA® Works™.